

Changing Landscapes

Thawing Permafrost

High School Guide

REACH Up

Raising Educational Achievement
through Cultural Heritage Up

Changing Landscapes

How does climate change impact the landscape?

The climate in the Bering Strait region of western Alaska is warming. Increasing temperatures change the landscape in a variety of ways. Landscape changes impact local ecosystems and ways of life for local residents. What are these changes? What processes cause them? How do these changes impact Bering Strait communities?

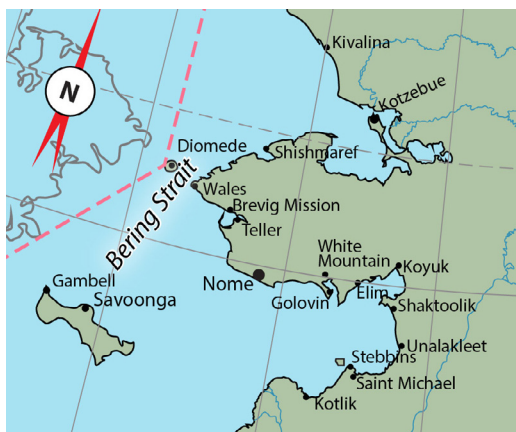

Bering Strait, Alaska

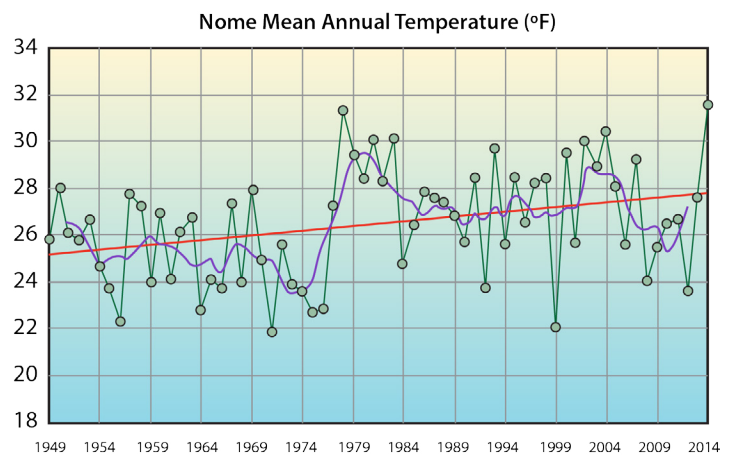

What happens when the ground thaws?

Sinkholes are forming on the tundra. Recent landslides gouge hills and cliffs. Buildings are settling unevenly. Lakes are disappearing or changing their boundaries. These

landscape changes can be traced to a single culprit: permafrost thaw.



Diomedes School is perched on permafrost. As the ground beneath the school thaws, workers must frequently adjust the foundation to ensure the school is supported.

Photo of Diomedes School from Gary Eckenweiler



Thawing Permafrost

What is permafrost?

Permafrost is ground that has remained frozen year-round for at least two years. Most of Alaska's permafrost has been frozen for much longer. It lies beneath a layer of soil known as the active layer. The active layer freezes during the winter and thaws during the summer. It insulates the permafrost from warm summer temperatures.

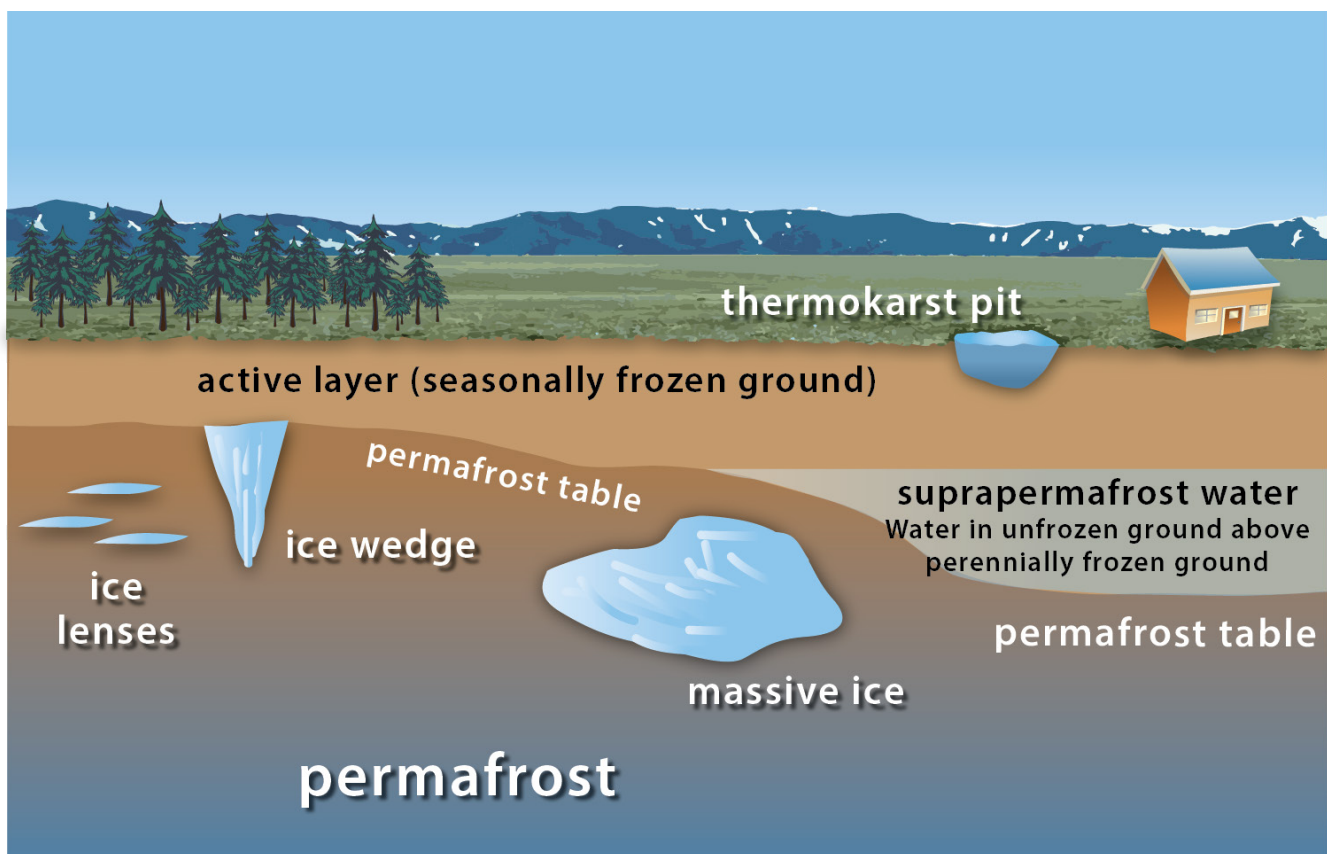

In the 1980s, a blanket of permafrost laid beneath the surface of most of Alaska. Today, much of Alaska's permafrost is thawing. A warming climate means the active layer is no longer adequate insulation for the permafrost. The thawing changes the landscape, because permafrost supports the soil, lakes and vegetation above it.

As permafrost thaws, water drains away and the ground becomes more vulnerable to erosion. In some areas, lakes drain through the newly porous ground, and habitats for plants, wildlife and people change.



Thawing Permafrost

Permafrost Change

Analyze the maps below. These maps show average annual soil temperatures at 1 meter depth in Alaska in 1980-1989 and projected soil temperatures for 2000-2009. Use the key on the map to determine which areas of the state have frozen soil year round. What trends do you notice? Can these trends be observed in your area?

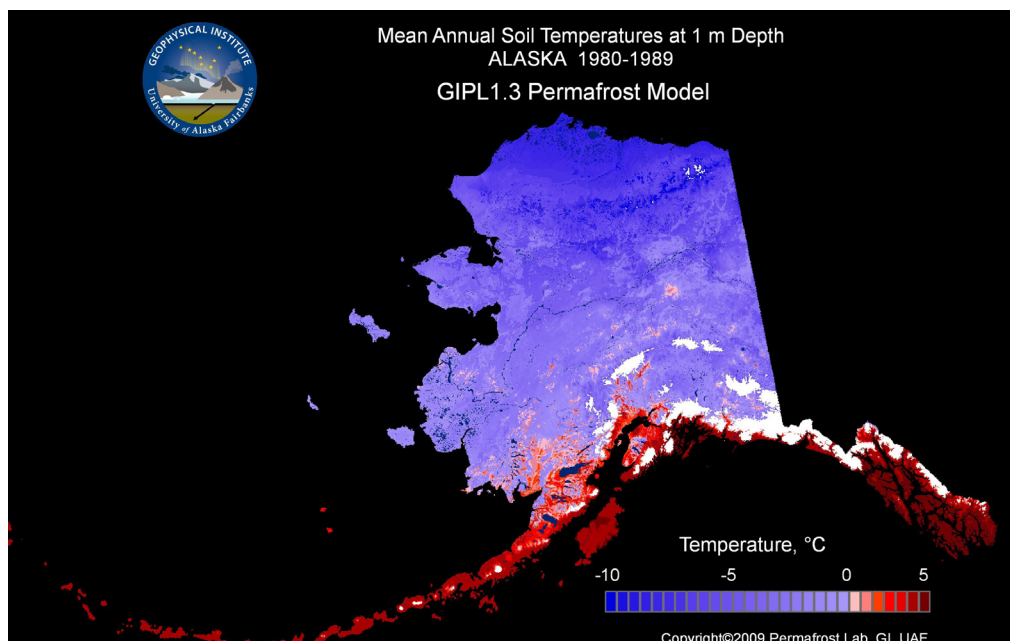

Modeling map of permafrost between 1980 and 1989, UAF Geophysical Institute.

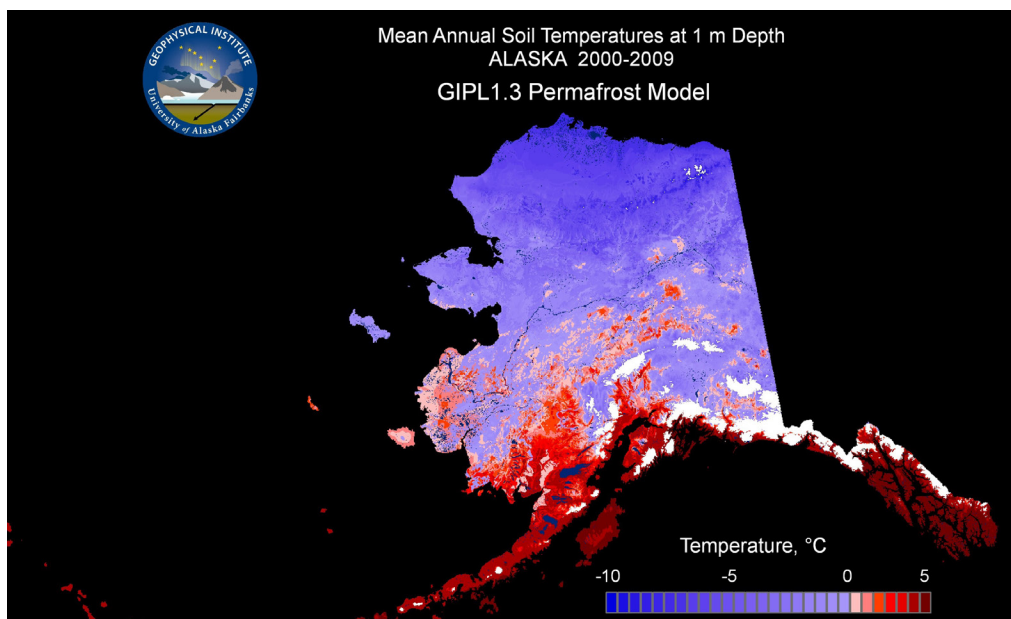

Model of projected permafrost between 2000 and 2009, UAF Geophysical Institute.



Ask an Expert

Is there permafrost in your area? What evidence of permafrost thaw have people seen in your region? How is permafrost thaw changing the landscape?

1. Watch the REACH UP *Permafrost Thaw* video located at www.k12reach.org/videos.php. As you watch, make a list of the qualitative observations of landscape changes related to permafrost thaw shared in the video.
2. Interview elders, scientists or other local knowledge bearers to collect more observations related to permafrost and add them to your list.
3. If the person you interview speaks an Alaska Native language, ask them what language and dialect(s) they are familiar with. Ask them to please translate the following words:
 - Permafrost
 - Ice
 - Lake
 - Ground

Compare your words with other translations found on the following page.

Are the terms the same or similar?



Marie Otten-Pete, Stebbins, AK



Permafrost Vocabulary

Would you like to know Alaska Native language terms related to climate change?

Work with your classmates to practice permafrost vocabulary words in English and the indigenous language of your community. Your teacher will give you vocabulary cards with the English word and an illustration on one side. Write the corresponding indigenous term on the blank line on the back of each card. Use the words that you learned from a local elder or cultural knowledge bearer, or choose the translation below that is closest to your community.

Miriam Toolie
Savoonga, AK
Siberian Yupik
St. Lawrence Island Yupik dialect
permafrost - kumlaneq
ice - siku
lake - naayvaq
ground - nuna

Annie Conger
Nome, AK (from Brevig Mission)
Seward Peninsula Iñupiaq
Bering Strait dialect
permafrost - atani / nunaam siku
ice - siku
lake - navrak
ground - nuna

Luci Washington
St. Michael, AK
Yup'ik
Unaliq dialect
permafrost - napat ngeliit
ice - ciku
lake - nunvaq
ground - cailkag

Jolene Nanouk
Unalakleet, AK
Seward Peninsula Iñupiaq
Qawiaraq dialect
permafrost - attaani / sikum nuna
ice - siku
lake - narvak
ground - nuna



How does permafrost thaw impact structures?

Homes, roads, schools and other structures built in permafrost areas are vulnerable to damage as permafrost thaws. Ice cellars dug into the permafrost collapse and can no longer be used to preserve food. Roads and boardwalks buckle. Buildings not engineered for permafrost lean and crack. Homes and businesses built near waterways are undercut by increased erosion.

Most of the Bering Strait region is underlain by discontinuous permafrost. This means that there is permafrost beneath 50-90% of the ground surface. Engineers and builders must plan for permafrost in this area. The foundation of a building affects how it is impacted by permafrost.

Permafrost Characteristics of Alaska

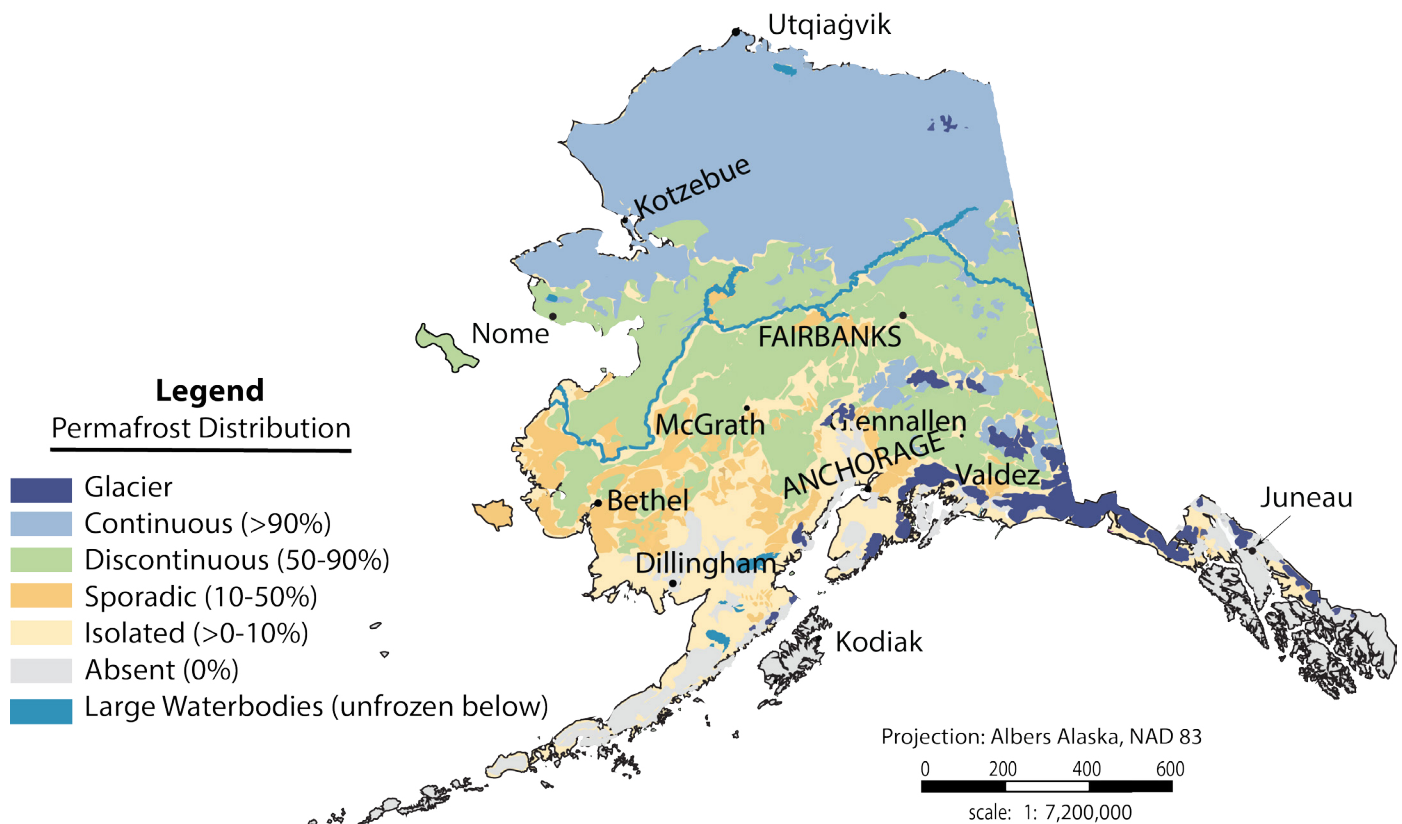

Based on Permafrost Characteristics of Alaska map. Jorgenson, et al.
<http://permafrost.gi.alaska.edu/content/data-and-maps>



Engineering for Permafrost

Multipoint Space Frame Foundation



Many small concrete pads support a metal framework, distributing the weight of the home and allowing cold air to circulate beneath. If one of the pads sinks, the other bracings continue to support the structure.

Driven Pile Foundation



Long posts are driven deep into the ground. The floor of the home is framed to perch above the ground, resting on the posts.

Post on Pad Foundation



Small concrete pads are constructed on prepared ground, with a post above each pad. The posts support the home, allowing cold air to circulate beneath.

Slab on Grade Foundation



A large concrete pad the same size as the footprint of the home is poured on prepared ground. The home is built on top of the slab. Heat from the home leaks into the concrete pad.



Engineering for Permafrost

How can we build lasting homes on permafrost? Plan from the bottom up!

A warming climate and heat from the home itself increase the likelihood of thawing permafrost beneath a home. The foundation of the home is key in determining how the building will impact and withstand permafrost thaw.

Modeling foundation types in permafrost conditions can help you determine which foundation options are best for your area. Work with classmates to build models of three foundation types:

- 1) Post on Pad;
- 2) Slab on Grade; and
- 3) Driven Pile.

Test the models by placing them in ice and gravel to represent soil with permafrost; then take measurements as the “permafrost” thaws.

Predict!

Which type of foundation do you think will work best in a permafrost area? Why? Which will be the least effective? Why?

Model it!

1. Build a model of one of the foundation types shown below. Others in your class will build the other two types.

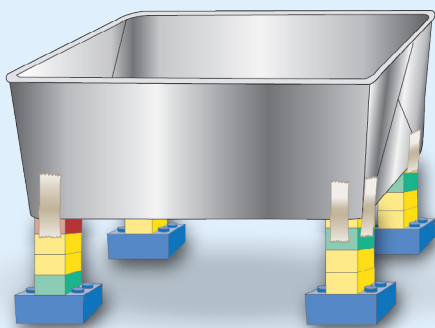

Post on Pad materials:

1 bread pan (house)
 16 square building bricks (posts)
 4 rectangular building bricks (pads)
 Tape

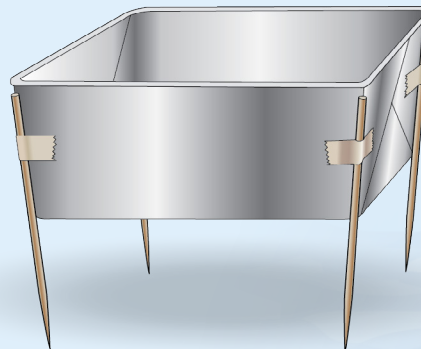

Driven Pile materials:

1 bread pan (house)
 4 skewers (pilings)
 Tape

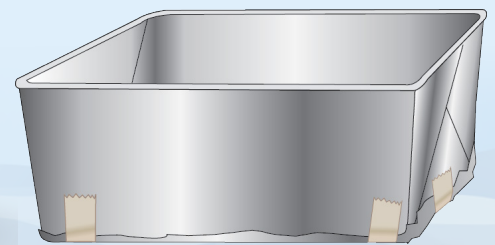

Slab on Grade materials:

1 bread pan (house)
 1 sheet of aluminum foil (slab)
 Tape



Activity

- Prepare your ground model in a plastic shoebox. Ice cubes will represent permafrost. Gravel will represent ground without permafrost. Calculate how much of each you will need to use for an accurate ground model in your area. Look at the chart to see what percentage of the ground is underlain by permafrost in your community. You will use 1,000 ml of “ground” for this activity. Hint: 100ml of “ground” equals 10%. How much gravel do you need? How much ice?

Ground model materials:

- 1 plastic shoebox
- Ice
- Gravel
- 1 measuring cup
- Ruler
- Hot water
- Timer

- Place your house model on your ground. *If you have the Driven Pile model, be sure to press the pilings into the ground as far as you can. Post and Pad and Slab on Grade models should rest on top of the ground.*
- Use a ruler to measure the height (from the ground) of the house at each end. Record your measurements.
- Pour hot water into your “house” and then repeat your measurements every 5 minutes. Did your house sink? If so, when? Why or why not?

Community	% of ground with permafrost
Brevig Mission	>90%
Diomedea	>90%
Elim	50-90%
Gambell	50-90%
Golovin	50-90%
Koyuk	50-90%
Savoonga	50-90%
Shaktolik	50-90%
Shishmaref	>90%
Stebbins	10-50%
St. Michael	10-50%
Teller	50-90%
Unalakleet	50-90%
Wales	>90%
White Mountain	10-50%

Make a conclusion!

Share your data with your classmates. Which type of foundation worked best? Why? How is energy transfer related to how each type of foundation affects the permafrost?

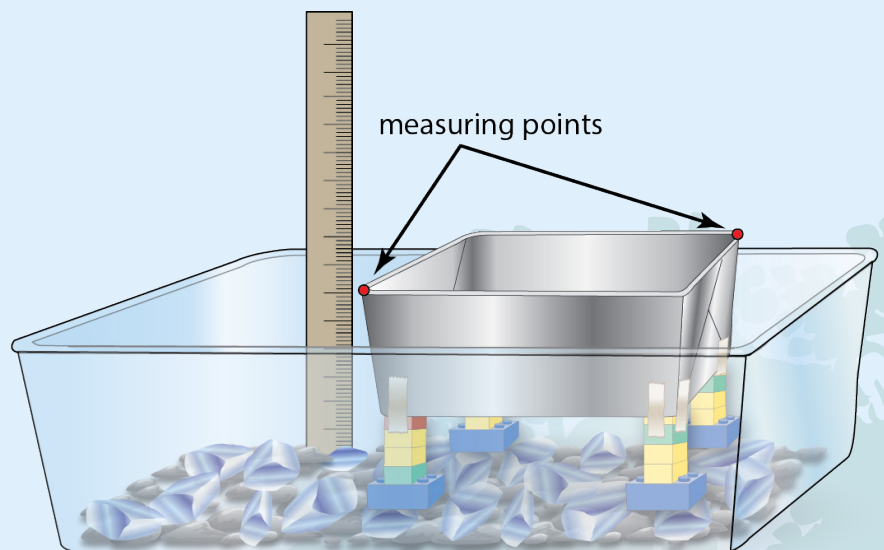

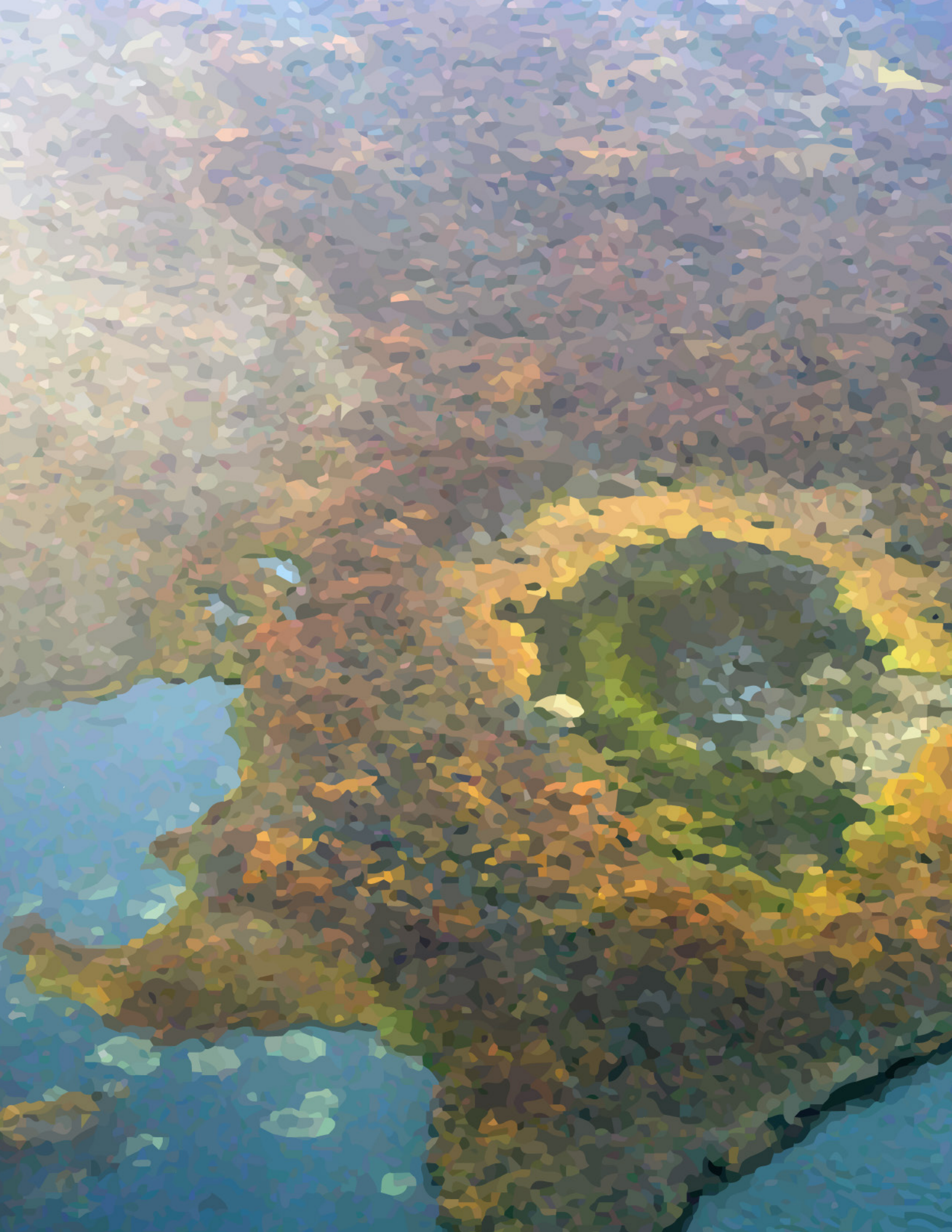



REACH Up, K-12 Outreach Office
School of Education, University of Alaska Fairbanks

P.O. Box 755400
Fairbanks, AK 99775

www.k12reach.org